

## **S-310 and S-314 Lift Platforms, and S-311, S-315 and S-316 Lift and Tip/Tilt Platforms, with Clear Aperture**



## Contents

<b>About this Document</b>	<b>4</b>
Symbols and Typographic Conventions.....	4
Other Applicable Documents .....	5
Downloading Manuals.....	5
<b>Safety</b>	<b>6</b>
Intended Use .....	6
General Safety Instructions .....	7
Organizational Measures.....	7
<b>Product Description</b>	<b>7</b>
Model Overview .....	7
Product View .....	8
Product Labeling.....	9
Scope of Delivery.....	10
Suitable Electronics .....	11
Control.....	12
Dynamic Behavior.....	15
Calculating Moments of Inertia for Mirror and Mirror Mount .....	15
Calculating the Resonant Frequency of the Tip/Tilt Platform.....	17
<b>Installation</b>	<b>19</b>
General Notes on Installation.....	19
Grounding the S-31x.....	20
Attaching the Mirror onto the S-31x .....	21
Mounting the S-31x .....	24
Connecting the S-31x to the Electronics.....	25
<b>Start-Up and Operation</b>	<b>26</b>
General Notes on Start-Up and Operation.....	26
Starting Up and Operating the S-31x.....	27
Discharging the S-31x .....	27

# User Manual



S310T0001, valid for S-310, S-311, S-314, S-315 and S-316  
KSch, 1/23/2018

---

<b>Maintenance</b>	<b>28</b>
<hr/>	
<b>Cleaning the S-31x</b>	<b>28</b>
<hr/>	
<b>Customer Service</b>	<b>29</b>
<hr/>	
<b>Technical Data</b>	<b>29</b>
<hr/>	
Data Table.....	29
Maximum Ratings.....	31
Ambient Conditions and Classifications .....	32
<hr/>	
<b>Dimensions</b>	<b>33</b>
<hr/>	
<b>Pin Assignment</b>	<b>34</b>
<hr/>	
Voltage Connection of S-31x.10 .....	34
Sensor Connection of S-316.10 .....	34
Voltage and Sensor Connection of S-316.10H.....	34
<hr/>	
<b>Old Equipment Disposal</b>	<b>36</b>
<hr/>	
<b>EU Declaration of Conformity</b>	<b>36</b>
<hr/>	

## About this Document

This user manual contains information necessary for the intended use of the S-31x platforms. It assumes that the reader has a fundamental understanding of basic servo systems as well as motion control concepts and applicable safety procedures.

This user manual is valid for the following products:

- S-310.10 lift platform
- S-314.10 lift platform
- S-311.10 lift and tip/tilt platform
- S-315.10 lift and tip/tilt platform
- S-316.10 and S-316.10H lift and tip/tilt platforms

## Symbols and Typographic Conventions

### CAUTION



#### Dangerous situation

If not avoided, the dangerous situation will result in minor injury.

- Actions to take to avoid the situation.

### NOTICE



#### Dangerous situation

If not avoided, the dangerous situation will result in damage to the equipment.

- Actions to take to avoid the situation.

### INFORMATION

Information for easier handling, tricks, tips, etc.

The following symbols and markings are used in the user manuals of PI:

Symbol	Meaning
1.	Action consisting of several steps whose sequential order must be observed
2.	
➤	Action consisting of one or several steps whose sequential order is irrelevant
▪	List item
S. 5	Cross-reference to page 5



Warning signs affixed to the product that refer to detailed information in this document.

## Other Applicable Documents

Product	Document
E-727.3SD/E-727.3SDA digital multi-channel piezo controllers for SGS	E727T0005 technical note
E-509.S3 sensor/servo controller module	PZ77E user manual
E-503.00S piezo amplifier module	PZ62E user manual
E-505.00 piezo amplifier module	
E-501.00 9.5" chassis for modular piezo controller system	
E-500.00 19" chassis for modular piezo controller system, 1 to 3 Channels	
E-518.I3 interface module	E518T0001 technical note, PZ214E user manual
E-610.S0 piezo controller/amplifier	PZ70E user manual
E-625.SR piezo servo controller for strain gauge sensors	PZ167E user manual

The current versions of the user manuals are available for download on our website.

## Downloading Manuals

### INFORMATION

If a manual is missing or problems occur with downloading:

- Contact our customer service department (p. 29).

### INFORMATION

For products that are supplied with software (CD in the scope of delivery), access to the manuals is protected by a password. Protected manuals are only displayed on the website after entering the password.

The password is included on the CD of the product.

### For products with CD: Identify the password

1. Insert the product CD into the PC drive.
2. Switch to the Manuals directory on the CD.
3. In the Manuals directory, open the Release News (file including *releasenews* in the file name).
4. Find the user name and the password in the section "User login for software download" in the Release News.

## Downloading Manuals

1. Open the website **www.pi.ws**.
2. If access to the manuals is protected by a password:
  - a) Click **Login**.
  - b) Log in with the user name and password.
3. Click **Search**.
4. Enter the product number up to the period (e.g., P-882) or the product family (e.g., PICMA® Bender) into the search field.
5. Click **Start search** or press the  key.
6. Open the corresponding product detail page in the list of search results:
  - a) If necessary: Scroll down the list.
  - b) If necessary: Click **Load more results** at the end of the list.
  - c) Click the corresponding product in the list.
7. Scroll down to the **Downloads** section on the product detail page.  
The manuals are displayed under **Documentation**.
8. Click the desired manual and save it to the hard disk of your PC or to a data storage medium.

## Safety

### Intended Use

Both S-310 and S-314 platforms provide motion along the Z axis, whereas S-311, S-315 and S-316 offer tip/tilt motion additionally. For details regarding travel ranges refer to "Model Overview" (p. 7).

Based on its design and realization, an S-31x platform is intended to position an optical component, as for example, a mirror with a typical load of 3 g to 6.5 g.

The S-31x platform can be mounted horizontally or vertically. It is a laboratory device as defined by DIN EN 61010-1. It is intended to be used in interior spaces and in an environment which is free of dirt, oil and lubricants.

The intended use of the S-31x platform is only possible in combination with suitable electronics that is available from PI.

## General Safety Instructions

The S-31x is built according to state-of-the-art technology and recognized safety standards. Improper use can result in personal injury and/or damage to the S-31x.

- Only use the S-31x for its intended purpose, and only use it if it is in a good working order.
- Read the user manual.
- Immediately eliminate any faults and malfunctions that are likely to affect safety.

The operator is responsible for the correct installation and operation of the S-31x.

## Organizational Measures

### User manual

- Always keep this user manual available with the S-31x.
- The latest versions of the user manuals are available for download (p. 5) on our website.
- Add all information from the manufacturer to the user manual, for example supplements or technical notes.
- If you give the S-31x to other users, also include this user manual as well as other relevant information provided by the manufacturer.
- Only use the device on the basis of the complete user manual. Missing information due to an incomplete user manual can result in minor injury and damage to equipment.
- Only install and operate the S-31x after you have read and understood this user manual.

### Personnel qualification

The S-31x may only be installed, started up, operated, maintained, and cleaned by authorized and appropriately qualified personnel.

## Product Description

### Model Overview

Model	Description
S-310.10	Piezo actuator, clear aperture, 6 $\mu\text{m}$ , LEMO connectors
S-311.10	Piezo Z/ tip/tilt platform, clear aperture, 600 $\mu\text{rad}$ , 6 $\mu\text{m}$ , LEMO connectors
S-314.10	Piezo actuator, clear aperture, 12 $\mu\text{m}$ , LEMO connectors
S-315.10	Piezo Z/ tip/tilt platform, clear aperture, 1.2 mrad, 12 $\mu\text{m}$ , LEMO connectors
S-316.10	Piezo Z/ tip/tilt platform, clear aperture, 1.2 mrad, 12 $\mu\text{m}$ , SGS, LEMO connectors
S-316.10H	Piezo Z/ tip/tilt platform, clear aperture, 1.2 mrad, 12 $\mu\text{m}$ , SGS, Sub-D 37-pin (m)

## INFORMATION

The open-loop models (S-310 to S-315) are ideal for applications where the position is controlled by an external loop based on data provided by a sensor (e.g. quad cell, CCD chip).

## Product View

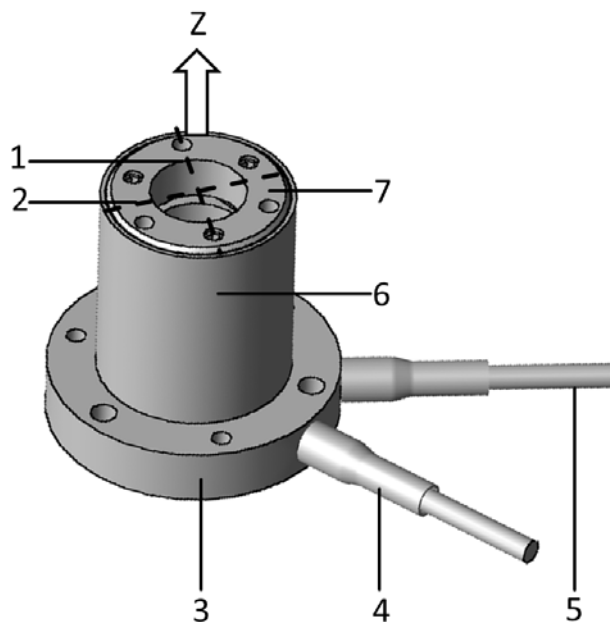

Figure 1: Example view of an S-316.10H

- 1 Axis X (corresponds to channel 1 on the E-727.3SD/A controller)\*
- 2 Axis Y (corresponds to channel 2 on the E-727.3SD/A controller)\*
- 3 Base body
- 4 Piezo voltage cable
- 5 Sensor cable (only S-316)
- 6 Housing
- 7 Motion platform with aperture

\* The assignment of the axes X and Y in Figure 1 only applies under the following conditions:





- It applies to the S-311, S-315, and S-316 models
- This lift and tip/tilt platform was calibrated at PI with electronics that can perform coordinate transformation (E-727.3SD/A)

Tilting is not possible with the S-310 and S-314 models.

If electronics are used that cannot perform coordinate transformation (e.g. E-509.S3 with E-503.00), the user must determine the assignment of axes himself and perform coordinate transformation separately.



## Product Labeling

Labeling	Description
S-316.10H	Product name (example), the characters following the period refer to the model
116010244	Serial number (example), individual for each S-31x Meaning of the places (counting from left): 1 = internal information 2 and 3 = year of manufacture 4 to 9 = consecutive numbers
	Manufacturer's logo
Country of origin: Germany	Country of origin
	Warning sign "Observe manual!"
	Old equipment disposal (p. 36)
	CE conformity mark
WWW.PI.WS	Manufacturer's address (website)
	Symbol for the protective earth conductor

### S-31x.10: Labeling of the LEMO connections

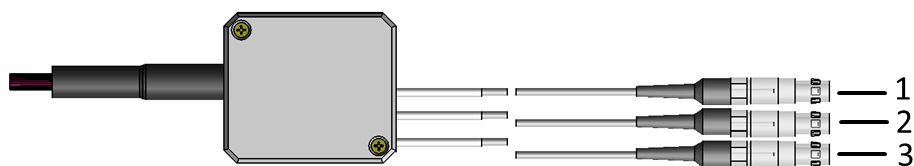

Figure 2: LEMO connections of the models without sensor

- 1 Piezo connection labeled **PZT1**
- 2 Piezo connection labeled **PZT2**
- 3 Piezo connection labeled **PZT3**

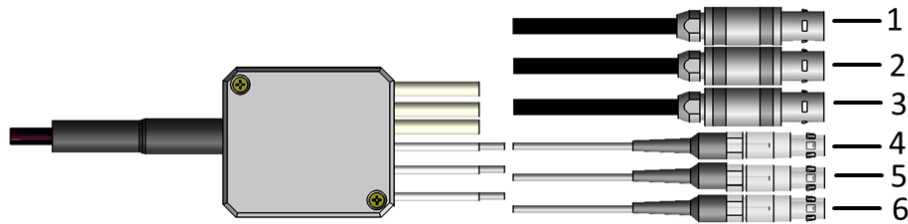



Figure 3: LEMO connections of S-316.10, model with sensor

- 1 Sensor connection labeled **CH1**
- 2 Sensor connection labeled **CH2**
- 3 Sensor connection labeled **CH3**
- 4 Piezo connection labeled **PZT1**
- 5 Piezo connection labeled **PZT2**
- 6 Piezo connection labeled **PZT3**

### S-316.10H: Labeling of the Sub-D 37 (m) connector



Figure 4: Sub-D 37 (m) connector on the connection cable of the S-316.10H

- 1  Warning sign "Residual Voltage": Notice of risk of electric shock (p. 7)

## Scope of Delivery

Item ID	Components
S-31x	Lift platform or lift and tip/tilt platform as specified in the order
PZ277EK	Short instructions for S-3xx piezo tip/tilt platforms

## Suitable Electronics

Model	Controller	Amplifier	Dimensions	Interfaces
S-316.10H	E-727.3SD digital multi-channel piezo controller, 3 channels, -30 to 130 V, sub-D 37 socket, strain gauge sensors		221 mm × 240.10 mm × 116.60 mm	-
	E-727.3SDA digital multi-channel piezo controller, 3 channels, -30 to 130 V, sub-D 37 socket, strain gauge sensors, analog inputs		221 mm × 240.10 mm × 116.60 mm	-
S-316.10	E-509.S3 sensor / piezo servo-control module, strain gauge sensors, 3 channels	E-503.00 piezo amplifier module, -30 to 130 V, 3 channels	E-501.00 9½" chassis for modular piezo controller system, 1 to 3 channels	Optional: E-518.I3 interface module, 3 channels, TCP/IP, USB and RS-232 interfaces
	E-509.S3 sensor / piezo servo-control module, strain gauge sensors, 3 channels	3 x E-505.00 piezo amplifier module, 2 A, -30 to 130 V, 1 channel	E-500.00 19" chassis for modular piezo controller system, 1 to 3 channels	Optional: E-518.I3 interface module, 3 channels, TCP/IP, USB and RS-232 interfaces
	E-610.S0 piezo controller/amplifier, OEM module, 1 channel, -30 to 130 V, SGS sensor		7 HP / 3 RU	-
	E-625.SR piezo amplifier / servo controller, 1 channel, -30 to 130 V, SGS sensor, USB, RS-232		205 mm × 105 mm × 60 mm	-
S-310.10, S-311.10, S-314.10, S-315.10	-	E-503.00 piezo amplifier module, -30 to 130 V, 3 channels	E-501.00 9½" chassis for modular piezo controller system, 1 to 3 channels	Optional: E-518.I3 interface module, 3 channels, TCP/IP, USB and RS-232 interfaces
	-	3 x E-505.00 piezo amplifier module, 2 A, -30 to 130 V, 1 channel	E-500.00 19" chassis for modular piezo controller system, 1 to 3 channels	Optional: E-518.I3 interface module, 3 channels, TCP/IP, USB and RS-232 interfaces
	-	3 x E-610.00 piezo amplifier, 1 channel, OEM module, -30 to 130 V	7 HP / 3RU	-

---

## Control

S-310 to S-316 tilt platforms are equipped with three low-voltage (0 to 100 V) piezo actuators spaced at 120° intervals.

With the S-310 and S-314 platforms only motion in Z axis is possible. Their three PZTs are electrically connected in parallel.

In addition, the S-311, S-315 and S-316 platforms provide tip/tilt motion. With these platforms all three PZTs can be driven individually.

Control of the tip/tilt versions is complicated because expansion of an individual piezo actuator can affect both  $\theta_X$  and  $\theta_Y$  rotation. Therefore the linear travel in Z and the tip/tilt angles in  $\theta_X$  and  $\theta_Y$  are interdependent.

External coordinate transformation (software or hardware) is required to allow platform position commands in  $\theta_X$  and  $\theta_Y$  coordinates.

An example for how to calculate the linear travel and the tip/tilt angles depending on the linear displacements of the piezo actuators is given below.

### Example calculation of linear travel and tip/tilt angles

There are many ways to define the axes and tip/tilt angles. The definitions you use will depend on the geometry of your application.

The geometry shown in Figure 5 and the calculation of distance  $a$  and the diameter  $\emptyset$  are based on a system with the Y-axis passing through one of the actuators (designated PZT3).

See also "Product View" on p. 8 for more information on assignment of axes.

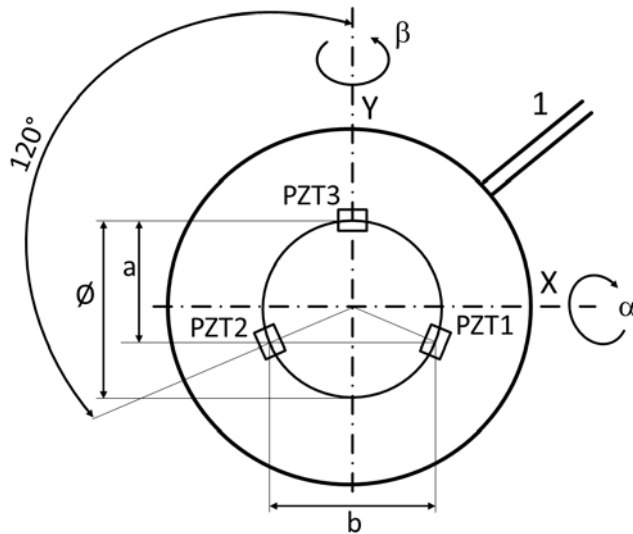

Figure 5: Triple-piezo-drive tip/tilt platform geometry, viewed from above.

1	Cable exit
X	X axis as defined by the calibration at PI
Y	Y axis as defined by the calibration at PI
PZT1 to PZT3	Piezo actuators
a	Distance between PZT3 and PZT2/PZT1 along the Y axis
b	Distance between PZT1 and PZT2
Ø	Diameter of circle of centers of the piezo actuators
α	Tilt angle around X axis, depending on linear displacement of the piezo actuators
β	Tilt angle around Y axis, depending on linear displacement of the piezo actuators

### Calculation of distance a and diameter Ø

$$a = \frac{b}{2} \sqrt{3} \quad \quad \quad \varnothing = \frac{2b}{3} \sqrt{3}$$

### Calculation of tip/tilt angles α and β and linear travel in Z

The following formulas show the relationship between the displacement of each piezo actuator (from the bottom limit of the travel range = extension at 0 V) and the tip/tilt angles (in radians). The formulas use the  $\sin \alpha = \alpha$  approximation, making it valid for small angles, covering the full travel range of the lift and tip/tilt platform.

$$\alpha = \frac{\left[ A - \frac{1}{2}(B+C) \right]}{a}$$

$$\beta = \frac{(B - C)}{b}$$

$$Z = \frac{(A + B + C)}{3}$$

with:

$\alpha$  = Tip/tilt angle in  $\theta_X$ , measured around axis X as defined by the calibration at PI [mrad]

$\beta$  = Tip/tilt angle in  $\theta_Y$ , measured around axis Y as defined by the calibration at PI [mrad]

A = Linear displacement of PZT3 [ $\mu\text{m}$ ]

B = Linear displacement of PZT2 [ $\mu\text{m}$ ]

C = Linear displacement of PZT1 [ $\mu\text{m}$ ]

Z = Linear displacement of the platform center (i.e. travel in Z axis)

## Example calculation for S-315 and S-316 lift and tip/tilt platforms

$\emptyset$  = 13.9 mm

a = 10.4 mm

b = 12.0 mm

A, B, C: 0 to 12  $\mu\text{m}$  (range of linear displacement of the piezo actuators)

$$\alpha_{\min} = \frac{\left(A_{\min} - \frac{1}{2}(B_{\max} + C_{\max})\right)}{a} = \frac{-12 \mu\text{m}}{10.4 \text{ mm}} = -1.15 \text{ mrad}$$

$$\alpha_{\max} = \frac{\left(A_{\max} - \frac{1}{2}(B_{\min} + C_{\min})\right)}{a} = \frac{12 \mu\text{m}}{10.4 \text{ mm}} = 1.15 \text{ mrad}$$

$$\beta_{\min} = \frac{(B_{\min} - C_{\max})}{b} = \frac{-12 \mu\text{m}}{12 \text{ mm}} = -1 \text{ mrad}$$

$$\beta_{\max} = \frac{(B_{\max} - C_{\min})}{b} = \frac{12 \mu\text{m}}{12 \text{ mm}} = 1 \text{ mrad}$$

$$Z = 0 \text{ to } 12 \mu\text{m}$$

## Dynamic Behavior

The maximum operating frequency of a piezo tip/tilt platform depends on the following factors:

- Bandwidth of amplifier, controller, and sensor
- Resonant frequency of the tip/tilt platform including mirror and where appropriate, mirror mount

The resonant frequency is estimated in two steps:

- a) Calculating the moments of inertia for mirror and mirror mount (p. 15)
- b) Calculating (p. 17) resonant frequency of the tip/tilt platform including mirror and mirror mount.

## Calculating Moments of Inertia for Mirror and Mirror Mount

### Calculating the distance from the axis through the center of gravity of the mirror to the rotational axis

Before the moment of inertia of the mirror is calculated, it is necessary to calculate the distance from the axis through the center of gravity of the mirror to the rotational axis of the platform. When a mirror mount is used, it must be included in the calculation.

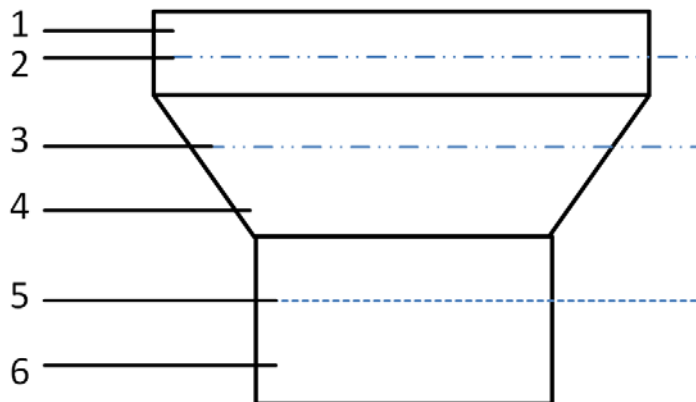

Figure 6: Example diagram: Platform with mirror mount and mirror

- 1 Mirror
- 2 Axis through the center of gravity of the mirror
- 3 Axis through the center of gravity of the mirror mount
- 4 Mirror mount (example of a geometry)
- 5 Axis through the pivot point of the platform of the S-335 ("rotational axis")
- 6 Platform

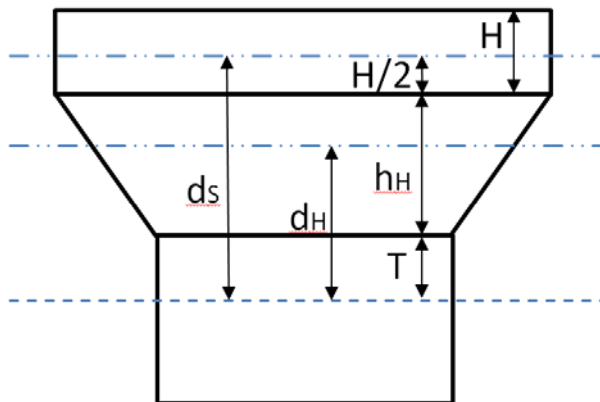

Figure 7: Example diagram: Platform with mirror mount and mirror; here with variables required for calculating the moments of inertia

- $d_s$  Distance from the axis through the center of gravity of the mirror to the rotational axis
- $d_H$  Distance from the axis through the center of gravity of the mirror mount to the rotational axis
- $H/2$  Half the mirror thickness
- $h_H$  Thickness of the mirror mount
- $T$  Distance from the rotational axis to the platform surface (see "Data Table" (p. 29))
- $H$  Mirror thickness

Formula for calculating the distance from the axis through the center of gravity of the mirror to the rotational axis of the platform:

When a mirror is attached **without** a mirror mount:

$$d_s = \frac{H}{2} + T$$

When a mirror is attached **with** a mirror mount:

$$d_s = \frac{H}{2} + h_H + T$$

with:

$d_s$  = Distance from the axis through the center of gravity of the mirror to the rotational axis [mm]

$H$  = Mirror thickness [mm]

$h_H$  = Thickness of the mirror mount [mm]

$T$  = Distance from the rotational axis to the platform surface [mm], see "Data Table" (p. 29)



## Calculating the moment of inertia of the mirror

Formula for calculating the moment of inertia of a rotationally symmetric mirror:

$$I_{S, P} = m_S \left[ \frac{3R^2 + H^2}{12} + d_S^2 \right]$$

Formula for calculating the moment of inertia of a rectangular mirror:

$$I_{S, P} = m_S \left[ \frac{L^2 + H^2}{12} + d_S^2 \right]$$

with:

$I_{S, P}$  = Moment of inertia of the mirror, in relation to the rotational axis [ $\text{g} \cdot \text{mm}^2$ ]

$m_S$  = Mirror mass [g]

$R$  = Mirror radius [mm]

$L$  = Mirror length perpendicular to the rotational axis [mm]

$H$  = Mirror thickness [mm]

$d_S$  = Distance from the axis through the center of gravity of the mirror to the rotational axis [mm]; for calculation see separate formulas (p. 15)

## Calculating the moment of inertia of the mirror mount

$$I_{H, P} = I_H + m_H * (d_H)^2$$

with:

$I_{H, P}$  = Moment of inertia of the mirror mount, in relation to the rotational axis [ $\text{g} \cdot \text{mm}^2$ ]

$I_H$  = Moment of inertia of the mirror mount, dependent on the geometry of the mirror mount [ $\text{g} \cdot \text{mm}^2$ ]

$m_H$  = Mass of the mirror mount [g]

$d_H$  = Distance from the axis through the center of gravity of the mirror mount to the rotational axis of the platform [mm], see above illustration (p. 15)

## Calculating the Resonant Frequency of the Tip/Tilt Platform

### Mirror without mirror mount

When the mirror is mounted without a mirror mount, the resonant frequency of the system is calculated with the following formula:

$$f' = \frac{f_0}{\sqrt{1 + \frac{I_{S,P}}{I_0}}}$$

with:

$f'$  = Resonant frequency of the S-335 with mirror [Hz]

$f_0$  = Resonant frequency of the unloaded S-335 [Hz]; see "Data Table" (p. 29)

$I_0$  = Moment of inertia of the platform of the S-335 [ $\text{g}\cdot\text{mm}^2$ ], see "Data Table" (p. 29)

$I_{S,P}$  = Moment of inertia of the mirror, in relation to the rotational axis, [ $\text{g}\cdot\text{mm}^2$ ]; calculation see separate formulas (p. 17)

## Mirror with mirror mount

When the mirror is mounted with a mirror mount, the resonant frequency of the tip/tilt platform is calculated with the following formula:

$$f' = \frac{f_0}{\sqrt{1 + \frac{(I_{S,P} + I_{H,P})}{I_0}}}$$

with:

$f'$  = Resonant frequency of the S-335 with mirror and mirror mount [Hz]

$f_0$  = Resonant frequency of the unloaded S-335 [Hz], see "Data Table" (p. 29)

$I_0$  = Moment of inertia of the platform of the S-335 [ $\text{g}\cdot\text{mm}^2$ ], see "Data Table" (p. 29)

$I_{S,P}$  = Moment of inertia of the mirror, in relation to the rotational axis, [ $\text{g}\cdot\text{mm}^2$ ]; for calculation see separate formulas (p. 17)

$I_{H,P}$  = Moment of inertia of the mirror mount, in relation to the rotational axis, [ $\text{g}\cdot\text{mm}^2$ ]; calculation see separate formula (p. 17)

Further information on dynamic or static operation can be found in the PI catalog (CAT 130), in the section "Fundamentals of Piezo Technology". The catalog can be downloaded from our website <http://www.pi.ws> under **Service > Downloads > Catalogs, Brochures & Certificates**.

## Installation

### General Notes on Installation

#### CAUTION



##### **Dangerous voltage and residual charge on piezo actuators!**

The S-31x is driven by piezo actuators. Mechanical shock, temperature changes and compressive stresses will cause high voltages to be developed. Touching the contacts of the S-31x can lead to minor injuries. In addition, the piezo actuators can be destroyed by an abrupt contraction.

- Do **not** open the S-31x.
- Discharge the piezo actuators of the S-31x before installation:  
Connect the S-31x to the switched-off PI controller for 10 seconds.
- Do **not** pull out the connector from the electronics during operation.

#### NOTICE



##### **Unsuitable cables!**

Unsuitable cables can damage the electronics.

- Only use cables from PI for connecting the S-31x to the electronics.

#### NOTICE



##### **Warping of the S-31x due to mounting on uneven surfaces!**

Mounting the S-31x on an uneven surface can warp the S-31x. Warping reduces the accuracy.

- Mount the S-31x on an even surface. The recommended evenness of the surface is  $\leq 30 \mu\text{m}$ .
- For applications with large temperature changes:  
Only mount the S-31x on surfaces that have the same or similar thermal expansion properties as the S-31x.

#### INFORMATION

Extended cables can affect the performance of the S-31x.

- If you need longer cables, contact our customer service department (p. 29).

## Grounding the S-31x

The S-31x does not feature a separate protective earth connection but must be connected conductively with a surface that is connected to a protective earth conductor.

### Requirements

- ✓ You have read and understood the safety precautions (p. 19).

### Tools and accessories

- Screws and alignment pins of suitable length, for details see “Mounting the S-31x” (p. 24)
- Suitable tool

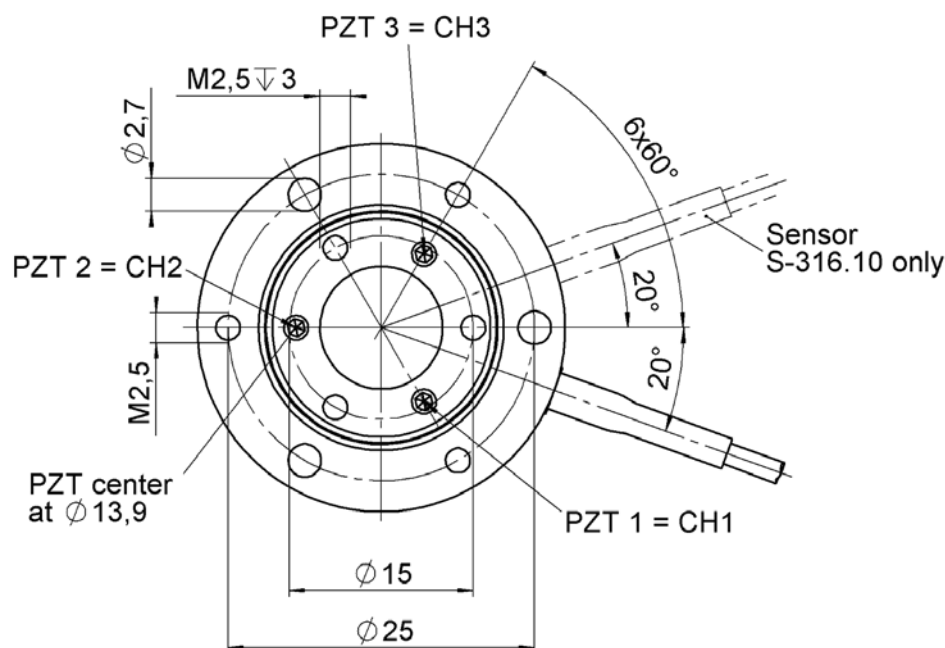

Figure 8: The three M2.5 through holes and the through holes with a  $\varnothing$  of 2.7 mm are to be used to mount the S-31x onto a surface that is connected to a protective earth conductor

## Grounding the S-31x

Attach the S-31x to a surface which is connected to a protective earth conductor:

1. Make sure that the contact resistance is  $<0.1$  ohm at 25 A at all connection points relevant for mounting the protective earth conductor.
2. Tighten the used M2.5 screws to the surface using the threaded mounting holes with at least three rotations and a torque of 0.6 Nm.

For further details refer to “Mounting the S-31x” (p. 24)

## Attaching the Mirror onto the S-31x

You can attach the mirror to the S-31x by two ways:

- Glue the mirror onto a mirror mount that can be mounted onto the platform using the three M2.5 mounting holes
- Glue the mirror directly onto the platform

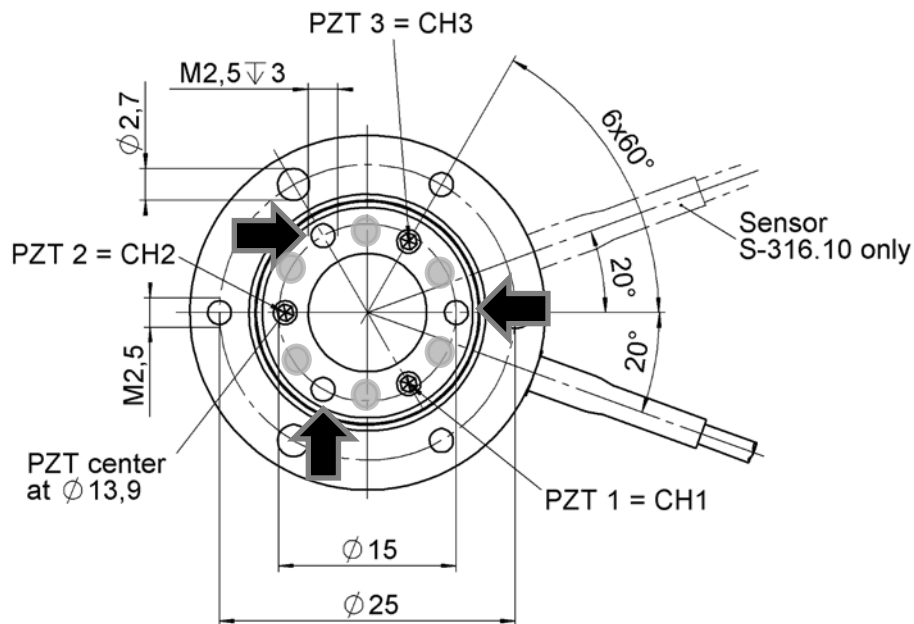

Figure 9: Gray areas mark where glue can be applied onto the S-31x, black arrows mark where to mount a mirror mount

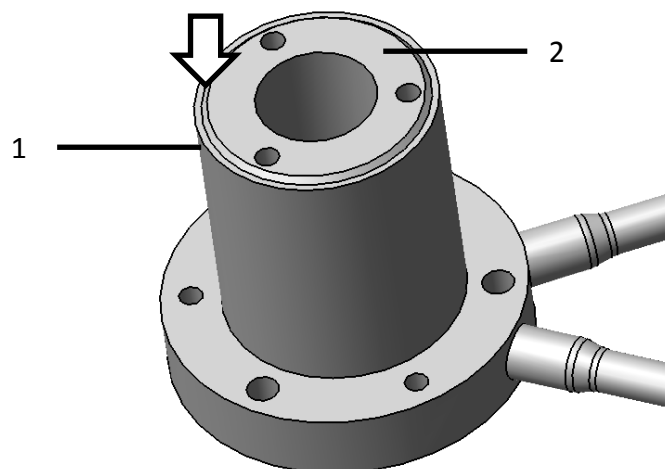

Figure 10: The arrow marks where adhesive **must not** enter

- 1 Housing
- 2 Motion platform

## NOTICE



### Excessively long screws!

The S-31x can be damaged by screws that are inserted too deeply.

- When selecting the screw length, observe the thickness of the mirror mount that is to be mounted.

## NOTICE



### Entering adhesive reduces accuracy!

When the mirror is glued directly onto the platform: adhesive that runs into the gap between the platform and the housing of the S-31x reduces the accuracy (see figure above).

- Ensure that adhesive cannot run into the gap between platform and housing, for example, by using a suitable mask that allows for punctiform applying of the adhesive.

## INFORMATION

Before gluing any mirror you should consider some important aspects:

- How flat does the mirror need to be? The greater the required flatness, the more care needs to be taken. This is primarily a matter of experience.
- Materials match: The platform of the S-31x is made of stainless steel 1.4305. Ideally, the mirror should have an identical thermal coefficient of expansion (CTE). The platform of the S-31x has a CTE of 16 ppm/K.
- Choose an adhesive that may be cured at room temperature (less stress is induced while drying/curing) and that shrinks as little as possible during the process.

## Requirements

- ✓ You have read and understood the safety precautions (p. 19).
- ✓ The S-31x is **not** connected to the controller.

## Tools and accessories

- Suitable mirror
- When the mirror is mounted using a mirror mount:
  - Suitable mirror mount
  - 3 M2.5 screws of suitable length
  - Suitable tool to fix mirror mount
- When the mirror is glued onto the platform:
  - Suitable adhesive, see above
  - Dosing apparatus
  - Option: Suitable positioning device for applying the adhesive
- Cotton swab
- Isopropanol

- Powder-free gloves

## Attaching the mirror onto the S-31x using a mirror mount

1. Attach the mirror mount onto the S-31x:
  - a) Optional: Align the mirror mount onto the platform using the 3 threaded pins.
  - b) Mount the mirror mount onto the platform of the S-31x using the three M2.5 screws.  
  
Pay attention to a **maximum screw-in depth of 3 mm**.  
  
**Maximum torque: 0.6 Nm**
2. Glue the mirror onto the mirror mount:
  - a) Insert a sufficient amount of adhesive on the mirror mount with a dosing apparatus. The adhesive must not be spoiled.
  - b) Align the mirror on the mirror mount.
  - c) Carefully and briefly press the mirror onto the mirror mount with a cotton swab.
  - d) If necessary, remove the adhesive residue with a cotton swab and isopropanol.
  - e) Allow the adhesive to harden according to the instructions of the adhesive manufacturer.

## Glueing the mirror onto the S-31x

1. Apply a sufficient amount of adhesive onto the platform:
  - a) If you use a mask for applying the adhesive: carefully align the mask on the platform of the S-31x and fix it in a suitable manner.
  - b) Apply a suitable amount of adhesive to three suitable points; see above figure. Only apply a pinhead-sized amount to each point.
  - c) If you use a positioning device for applying the adhesive: remove it.
2. Glue the mirror onto the platform:
  - a) Carefully place the mirror in a suitable orientation on the platform. Avoid touching the mirror surface.
  - b) Carefully and briefly press the mirror onto the motion platform with a cotton swab.
  - c) If necessary, remove the adhesive residue with a cotton swab and isopropanol.
  - d) Allow the adhesive to harden according to the instructions of the adhesive manufacturer.

## Mounting the S-31x

The S-31x can be mounted in any orientation. It can be mounted either from above or from below.

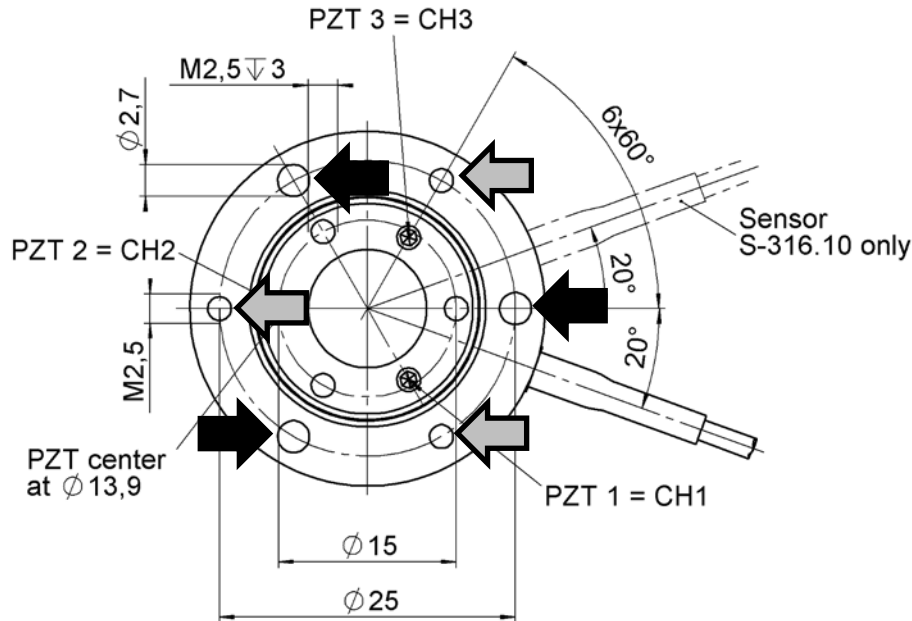

Figure 11: Arrows indicate where to mount the S-31x

Black arrows: Through holes for M2.5 screws, for mounting from above

Gray arrows: Threaded holes for M2.5 screws, for mounting from below

### Tools and accessories

- 6 x M2.5 screws of appropriate length
- Suitable tool
- Suitable surface

### Requirements

- ✓ You have provided a suitable installation environment:
  - The surface is connected to a protective earth conductor
  - The flatness of the surface is  $\leq 30 \mu\text{m}$ .
- ✓ The S-31x is **not** connected to the controller

### Mounting the S-31x

- Mount the S-31x using the mounting holes labeled by arrows, see Figure 11.



## Connecting the S-31x to the Electronics

### Requirements

- ✓ You have read and understood the safety precautions (p. 19).
- ✓ You have installed a suitable electronics (p. 31).
- ✓ You have read and understood the user manual of the electronics.
- ✓ The electronics is switched off.

### Connecting the S-316.10H to the E-727.xSD controller

1. Plug the connector of the S-316.10H into the corresponding socket of the controller (see user manual of the controller).
2. Use the integrated screws to secure the connection against accidental disconnection.

### Connecting the S-31x.10 to E-50x modules

1. Connect the piezo connectors of the S-31x.10 with the piezo amplifier modules as follows.

If you use an E-503.00S module:

- PZT1 to PZT for channel 1 (CH1)  
Only with S-311, S-315 and S-316:
- PZT2 to PZT for channel 2 (CH2)
- PZT3 to PZT for channel 3 (CH3)

If you use three E-505.00 modules for variable voltages:

- PZT1 to PZT of an E-505.00 module  
Only with S-311, S-315 and S-316:
- PZT2 to PZT of the second E-505.00 module
- PZT3 to PZT of the third E-505.00 module

2. Connect the sensor connections of the S-316.10 to the E-509.S3 servo-controller module as follows:
  - CH1 to SENSOR for channel 1 (SERVO 1)
  - CH2 to SENSOR for channel 2 (SERVO 2)
  - CH3 to SENSOR for channel 3 (SERVO 3)

## Start-Up and Operation

### General Notes on Start-Up and Operation

#### CAUTION



##### **Risk of electric shock if the protective earth conductor is not connected!**

If a protective earth conductor is not or not properly connected, dangerous touch voltages can occur on the S-31x in the case of malfunction or failure of the system. If touch voltages exist, touching the S-31x can result in minor injury from electric shock.

- Connect the S-31x to a protective earth conductor before start-up.
- Do not remove the protective earth conductor during operation.
- Use electrically conductive materials (e.g. screws and flat washers) for mounting the protective earth conductor.
- Make sure that the contact resistance is  $< 0.1$  ohm at 25 A at all connection points relevant for mounting the protective earth conductor.
- If the protective earth conductor has to be temporarily removed (e.g. for modifications), reconnect the S-31x to the protective earth conductor before starting it up again.

#### NOTICE



##### **Destruction of the piezo actuator by electric flashovers!**

The use of the S-31x in environments that increase the electrical conductivity can lead to the destruction of the piezo actuator by electric flashovers. Electric flashovers can be caused by moisture, high humidity, liquids and conductive materials such as metal dust. In addition, electric flashovers can also occur in certain air pressure ranges due to the increased conductivity of the air.

- Avoid operating the S-31x in environments that can increase the electric conductivity.
- Only operate the S-31x within the permissible ambient conditions and classifications (p. 32).

#### NOTICE



##### **Destruction of the piezo actuator by continuously high voltage!**

The constant application of high voltage to piezo actuators can lead to leakage currents and flashovers that destroy the ceramic.

If the S-31x is not used, but the controller is to remain switched on to ensure temperature stability:

- Set the piezo voltage to 0 V on the controller.

## NOTICE



### Uncontrolled oscillation!

Oscillations can cause irreparable damage to the S-31x. Oscillations are indicated by a humming and can result from the following causes:

- The load and/or dynamics of operation differ too much from the calibration settings. Note that any mass mounted on the platform will reduce the resonant frequency.
- The S-31x is operated near its resonant frequency.
- If you notice oscillations, stop the S-31x immediately.

## INFORMATION

- For maximum tilt range of the tip/tilt versions, the optimum zero tip/tilt position is when all three piezo actuators are biased at 50 V.
- Linear travel and tilt angle are interdependent (see “Control” on p. 12). The travel and tip/tilt angles given in the data table (p. 29) refer to pure linear or pure angular motion.

## INFORMATION

In dynamic applications it is important to avoid exceeding the power-output capability of the amplifier. You can check this using the section “Continuous dynamic operation” (p. 60 -61) in the PI catalog “Piezo Actuators” (CAT128).

The catalog can be downloaded from our website <http://www.pi.ws> under **Service > Downloads > Catalogs, Brochures & Certificates**.

- If required contact our customer service department (p. 29).

## Starting Up and Operating the S-31x

### Requirements

- ✓ You have read and understood the following sections:
  - Safety Precautions (p. 19)
  - General Notes on Start-Up and Operation (p. 26)

### Starting up and operating the S-31x

- Follow the instructions in the manual of the used electronics for start-up and operation of the S-31x.

## Discharging the S-31x

The S-31x must be discharged in the following cases:

- When the S-31x is not used but the controller remains switched on to ensure temperature stability

- Before demounting (e.g. before cleaning and transport of the S-31x and for modifications of the application)
- Before pulling out the connector of the S-31x

## Discharging the S-31x that is connected to the controller

If you are working in closed-loop operation:

1. Switch off the servo mode on the controller.
2. Set the piezo voltage to 0 V on the controller.

If you are working in open-loop operation:

- Set the piezo voltage to 0 V on the controller.

## Discharging the S-31x that is not connected to the controller

- Connect the tip/tilt platform to the switched-off controller for 10 seconds.

## Maintenance

### NOTICE



#### Misalignment from loosening screws!

The S-31x is maintenance-free and precisely aligned.

- Do not loosen any sealed screws on the S-31x.

## Cleaning the S-31x

### NOTICE



#### Cleaning can damage the S-31x!

When liquid enters the S-31x the integrated piezo actuators are destructed by electric flashovers.

- Ensure that no liquid can enter the S-31x.
- Only clean the S-31x as described in the following section.

### Requirements

- ✓ You have discharged the piezo actuators of the S-31x.
- ✓ You have disconnected the S-31x from the controller.

### Cleaning the S-31x

- Clean the surface of the S-31x with a towel that is lightly dampened with a mild cleanser or disinfectant, with ethanol or with isopropanol.
- Do **not** do any ultrasonic cleaning.

## Customer Service

For inquiries and orders, contact your PI sales engineer or send us an e-mail ([service@pi.de](mailto:service@pi.de)).

If you have questions concerning your system, have the following information ready:

- Product codes and serial numbers of all products in the system
- Firmware version of the controller (if present)
- Version of the driver or the software (if present)
- Operating system on the PC (if present)

The latest versions of the relevant user manuals for your system are available for download on our website (<http://www.pi.ws>).

## Technical Data

### Data Table

	S-310.10	S-314.10	S-311.10	S-315.10	S-316.10 S-316.10H	Unit	Tolerance
Active axes	Z	Z	Z, $\theta X$ , $\theta Y$	Z, $\theta X$ , $\theta Y$	Z, $\theta X$ , $\theta Y$		
<b>Motion and positioning</b>							
Integrated sensor	-	-	-	-	SGS		
Open-loop travel in Z at 0 to 100 V	6	12	6	12	12	$\mu\text{m}$	min. (+20 %/ -0 %)
Open-loop tip/tilt angle, 0 to 100 V	-	-	600	1200	1200	$\mu\text{rad}$	min. (+20 %/ -0 %)
Closed-loop travel in Z	-	-	-	-	12	$\mu\text{m}$	
Closed-loop tip/tilt angle	-	-	-	-	1200	$\mu\text{rad}$	
Open-loop resolution in Z	0.1	0.2	0.1	0.2	0.2	nm	typ.
Open-loop resolution in $\theta X$ , $\theta Y$	-	-	0.02	0.05	0.05	$\mu\text{rad}$	typ.
Closed-loop resolution in Z	-	-	-	-	0.4	nm	typ.
Closed-loop resolution in $\theta X$ , $\theta Y$	-	-	-	-	0.1	$\mu\text{rad}$	typ.
Linearity error	-	-	-	-	0.2	%	typ.

# User Manual



S310T0001, valid for S-310, S-311, S-314, S-315 and S-316

KSch, 1/23/2018

	S-310.10	S-314.10	S-311.10	S-315.10	S-316.10 S-316.10H	Unit	Tolerance
<b>Mechanical properties</b>							
Stiffness in Z	20	10	20	10	10	N/μm	±20 %
Resonant frequency, no load, in Z	9.5	5.5	9.5	5.5	5.5	kHz	±20 %
Resonant frequency, under load (with 15 mm x 4 mm glass mirror)	6.5	4.4	6.5	4.1	4.1	kHz	±20 %
Resonant frequency, under load (with 20 mm x 4 mm glass mirror)	6.1	4.2	6.1	3.4	3.4	kHz	±20 %
Gap from pivot point to platform surface	-	-	5	5	5	mm	±1 mm
Platform moment of inertia	-	-	150	150	150	g × mm <sup>2</sup>	±20 %
<b>Drive properties</b>							
Ceramic type	PICMA® P-882	PICMA® P-882	PICMA® P-882	PICMA® P-882	PICMA® P-882		
Electrical capacitance	0.39	0.93	0.39 (0.13 per axis)	0.93 (0.31 per axis)	0.93 (0.31 per axis)	μF	±20 %
<b>Miscellaneous</b>							
Material	Steel	Steel	Steel	Steel	Steel		
Mass	0.053	0.055	0.045	0.055	0.055	kg	±5 %
Cable length	2	2	2	2	2	m	±10 mm
Voltage connection	LEMO	LEMO	LEMO	LEMO	S-316.10: LEMO S-310.10H: Sub-D 37 (m)		
Sensor connection	-	-	-	-	LEMO S-310.10H: Sub-D 37 (m)		



Resolution of S-31xs is not limited by friction or stiction. Value given is noise equivalent motion with E -503 amplifier.

Mechanical tilt, optical beam deflection is twice as large. For maximum tilt range, all three piezo actuators must be biased at 50 V. Due to the parallel- kinematics design, linear travel and tilt angle are interdependent. The values quoted here refer to pure linear / pure angular motion (equations).

## Recommended controller / amplifier:

- **Single- channel** (1 per axis): E -610 servo controller / amplifier, E -625 servo controller, bench- top
- **Multi- channel:**
  - Digital:** E-727.3SD piezo controller (three channels), E-727.3SDA piezo controller with analog inputs (three channels), E-727.4SD (four channels)
  - Analog:** modular piezo controller system E-500 with amplifier module E-503 (three channels) or E-505 (1 per axis, high- power) and E-509 controller (optional), E-518 interface module (optional)

## Maximum Ratings

Model	Maximum operating voltage 	Maximum operating frequency (with 15 mm x 4 mm glass mirror, at 100 V <sub>pp</sub> ) <sup>1</sup> 	Maximum power consumption <sup>2</sup> (for all axes, at 1 kHz) 
S-310.10	0 to +100 V	1 kHz	6.39 W
S-314.10	0 to +100 V	1 kHz	12.81 W
S-311.10	0 to +100 V	1 kHz	2.13 W
S-315.10	0 to +100 V	1 kHz	4.27 W
S-316.10/.10H	0 to +100 V	1 kHz	4.27 W

<sup>1</sup> To ensure stable operation, the maximum operating frequency is defined as approximately 1/3 of the mechanical resonant frequency.

<sup>2</sup> The heat generated by the piezo actuator during dynamic operation limits the value for maximum power consumption.

Details can be found online:

<http://piceramic.com/piezo-technology/properties-piezo-actuators/electrical-operation.html>

## Ambient Conditions and Classifications

Area of application	For indoor use only
Maximum altitude	2000 m
Air pressure	1100 hPa to 0.1 hPa (corresponds to roughly 825 Torr to 0.075 Torr)
Relative humidity	Highest relative humidity 80 % for temperatures up to 31 °C Decreasing linearly to 50 % relative humidity at 40 °C
Operating temperature	-20 °C to 80 °C
Storage temperature	-20 °C to 80 °C
Transport temperature	-25 °C to 85 °C
Overvoltage category	II
Protection class	I
Degree of pollution	1
Degree of protection according to IEC 60529	IP20



## Dimensions

Dimensions in mm. Note that the decimal places are separated by a comma in the drawings.

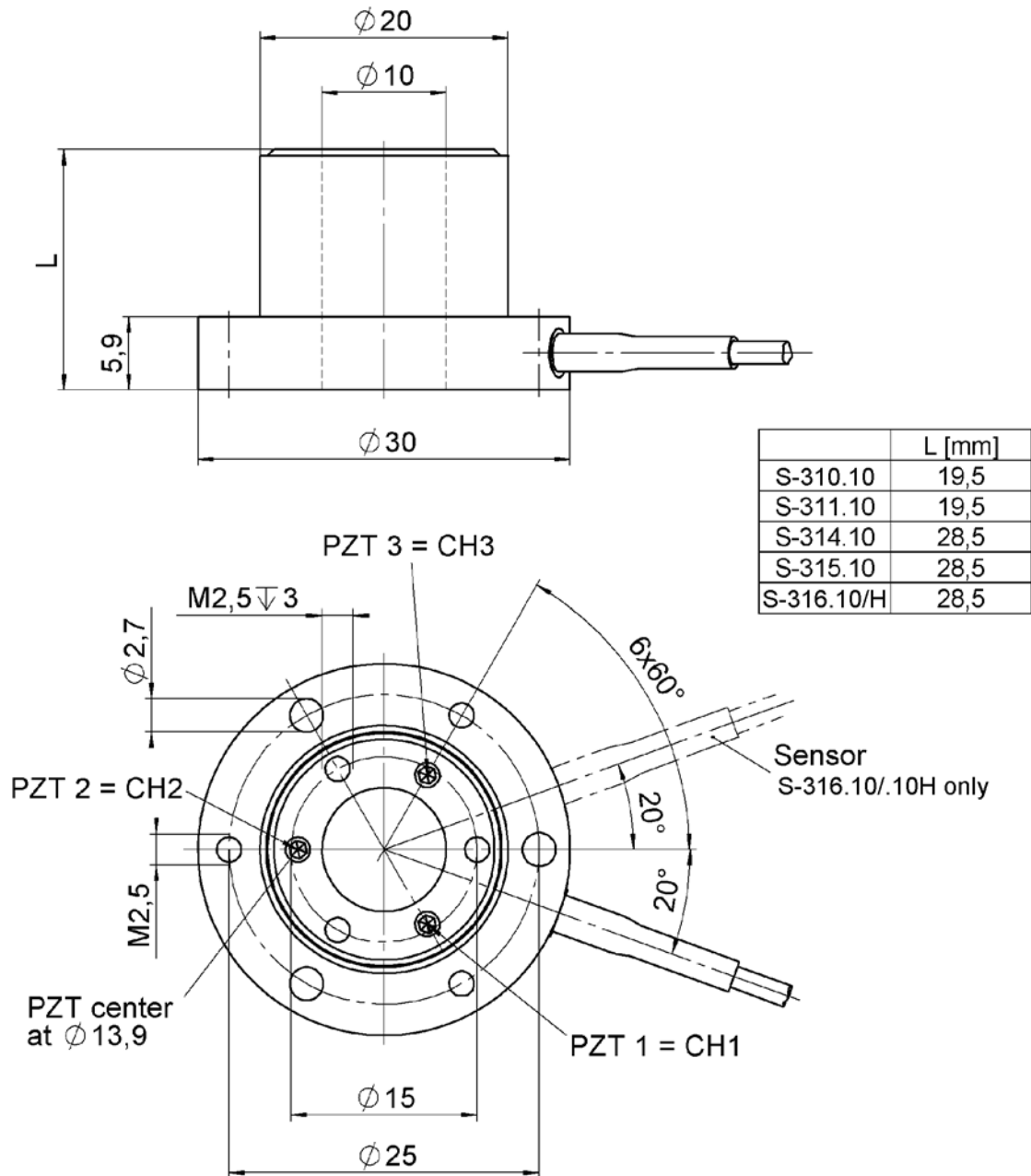

Figure 12: S-31x

## Pin Assignment

### Voltage Connection of S-31x.10

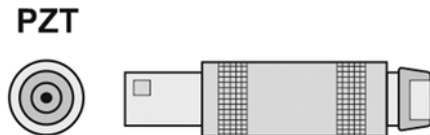

Figure 13: Piezo connector

Signal	Function	Connector Shell
PZT	Piezo Voltage	Ground

### Sensor Connection of S-316.10



Figure 14: Sensor connection: LEMO connector FFA.05.304.CLAC32Y, contact side

Pin	Signal	Function
1	SGS Ref	SGS reference
2	SGS-	SGS signal (negative)
3	SGS+	SGS signal (positive)
4	SGS GND	Ground SGS signal

### Voltage and Sensor Connection of S-316.10H



Figure 15: Voltage and sensor connection, sub-D 37 (m)

Pin	Signal	Function
1	-	-
2	GND	Ground
3	ID chip CH2	Data, ID chip CH2
4	-	-
5	ID chip GND	Ground, ID chip
6	-	-
7	GND	Ground
8	-	-
9	GND	Ground
10	SGS CH2+	SGS signal CH2+ (positive)
11	GND	Ground
12	SGS CH1+	SGS signal CH1+ (positive)
13	GND	-
14	Reserved	Reserved
15	Reserved	Reserved
16	Piezo CH1+	Piezo voltage, CH1+ (positive)
17	Piezo CH2+	Piezo voltage, CH2+ (positive)
18	Piezo CH3+	Piezo voltage, CH3+ (positive)
19	-	-
20	-	-
21	ID chip CH1	Data, ID chip CH1
22	ID chip GND	Ground, ID chip
23 to 27	-	-
28	SGS CH2-	SGS signal CH2- (negative)
29	SGS CH2 Ref	SGS reference CH2
30	SGS CH1-	SGS signal CH1- (negative)
31	SGS CH1 Ref	SGS reference CH1
32	Reserved	Reserved
33	Reserved	Reserved
34	Piezo CH1-	Piezo voltage, CH1- (negative)
35	Piezo CH2-	Piezo voltage, CH2- (negative)
36	Piezo CH3-	Piezo voltage, CH3- (negative)
37	-	-

---

## Old Equipment Disposal

In accordance with the applicable EU law, electrical and electronic equipment may not be disposed of with unsorted municipal wastes in the member states of the EU.

When disposing of your old equipment, observe the international, national and local rules and regulations.

To meet the manufacturer's product responsibility with regard to this product, Physik Instrumente (PI) GmbH & Co. KG ensures environmentally correct disposal of old PI equipment that was first put into circulation after 13 August 2005, free of charge.

If you have old PI equipment, you can send it postage-free to the following address:

Physik Instrumente (PI) GmbH & Co. KG

Auf der Roemerstr. 1

D-76228 Karlsruhe, Germany



## EU Declaration of Conformity

For the S-31x lift and/or tip/tilt platforms, an EU Declaration of Conformity has been issued in accordance with the following European directives:

Low Voltage Directive

EMC Directive

RoHS Directive

The applied standards certifying the conformity are listed below.

Safety (Low Voltage Directive): EN 61010-1

EMC: EN 61326-1

RoHS: EN 50581